

# BW-Fixatoren®

## Serie LS

...for the Levelling  
and Fixation of  
Light Machinery and  
Additional Sets

Installation Varieties and  
Technical Information



**BWF**

*...the best for accuracy.*

# Dimensions and Technical Data of Serie LS

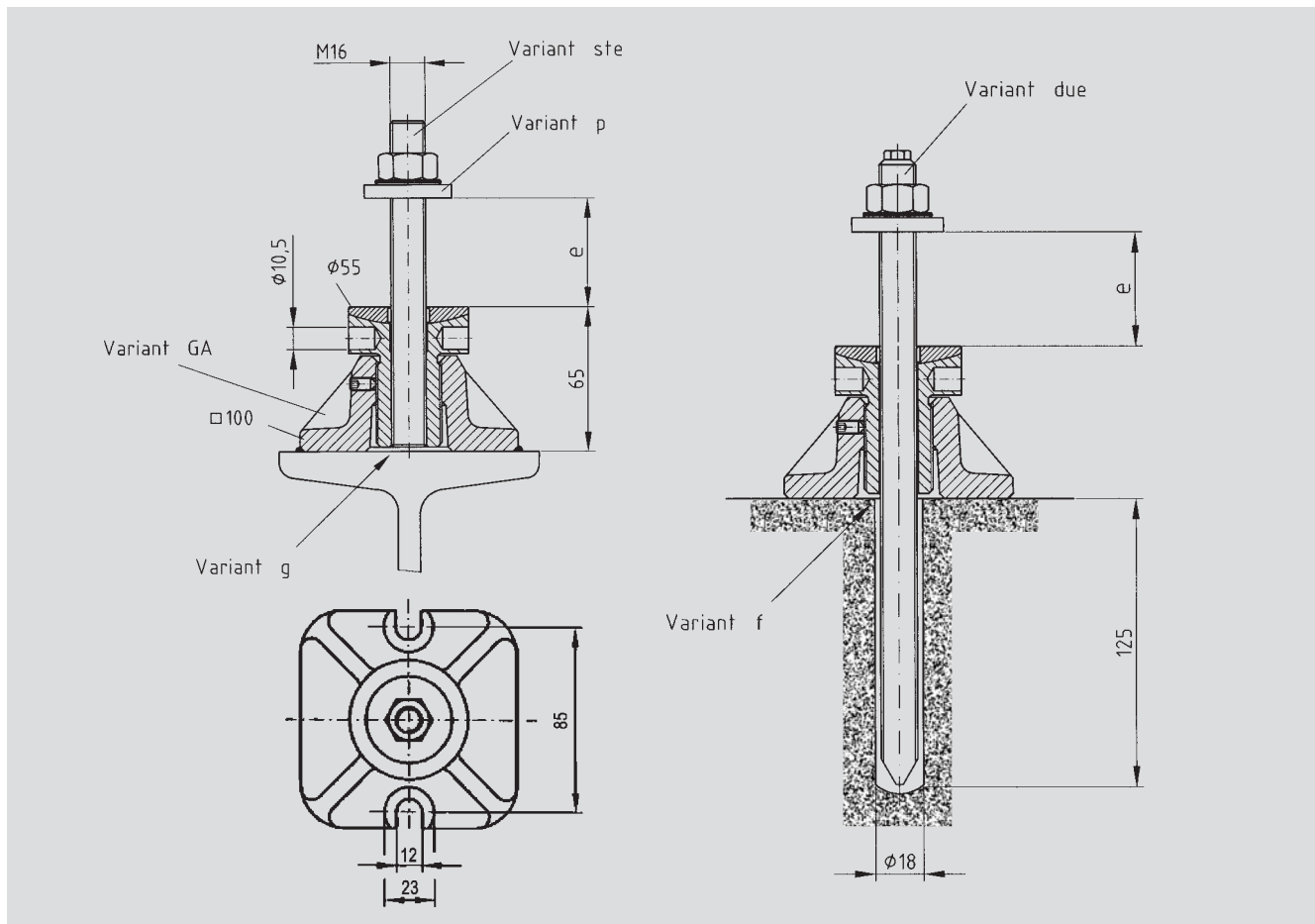

## Description

### GA

consists of the housing, threaded levelling element and spherical bearing plate

### g

levelling element with inside thread M16

### f

levelling element with inside hole  $\varnothing 17$

### ste

clamping stud M16 x 150 for max.  $e = 80$  mm

### due

resin anchor, capsule and stud M16 x 300 for max.  $e = 60$  mm

### p

Spherical washer set for non-parallel bearing surfaces  $\varnothing 40 \times 10$

### c

Side anchor bolts for connecting BW-Fixator® to the foundation, 2 resin anchors and 2 studs M16 x 130 (not shown)

## Technical Data

Permissible maximum load	25 KN
Permissible maximum lifting load	10 KN
Specific torque at levelling screw	45 Nm/10 <sup>3</sup> kg
Vertical Adjustment per screw turn	1,5 mm
Max. Adjustment	30 mm
Weight	1,6 kg

*Subject to modification without notice*