

BW-Fixatoren®

Series LK

...for anti-vibration
installation
of machines

Installation Varieties and
Technical Information



BWF
...the best for accuracy.

Dimensions of Series LK

GA Basic unit

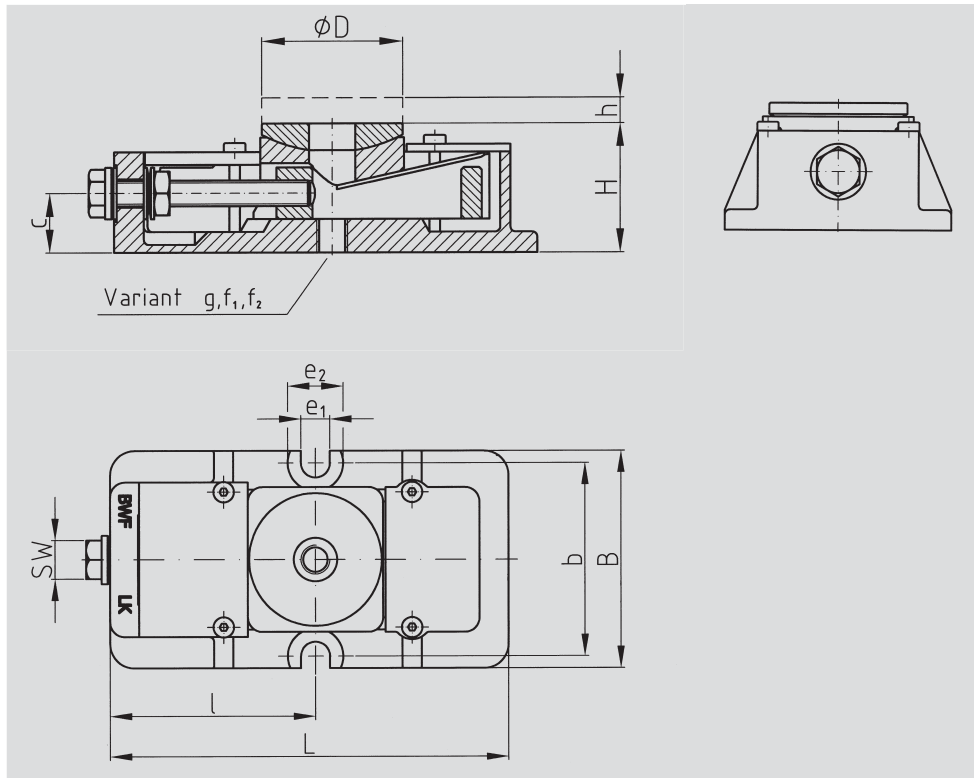

Size	L	B	H	ϕD	SW	h	l	b	e1	e2	c
I	165	90	50	55	17	10	85	80	12	23	23
II	195	110	60	70	19	10	100	95	14	26	28

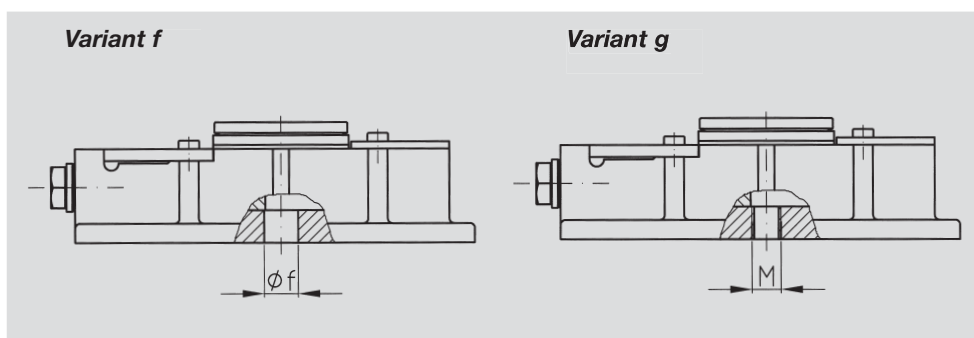

Size	f1	f2	M
I	13	17	M12
II	17	19	M16

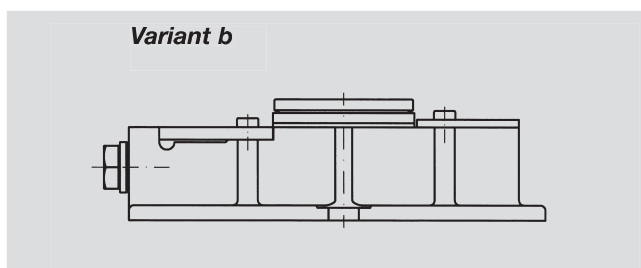

b
Machined bottom of the housings, the height is 2 mm less

Technical Data for Series LK

Size	Dim	LK I	LK II
Permissible maximum load	N	30 000	55 000
Permissible maximum lifting load	N	20 000	40 000
Torque at adjusting screw	Maximum	N·m	20
	Security	N·m	3 – 5
Vertical Adjustment per screw turn	mm	0,32	0,37
Weight of basic unit	kg	2,5	4,2

Note: The BW-Fixators® LK cannot adjusted with the anchor nut tightened

Determining BW-Fixator® Sizes

Divide the total load (machine weight and workpiece) by the number of bearing points to determine the average load per mount. Select a mount size with an equal or greater recommended static load.

For machinery with sizable variations in partial weight, it is the heaviest machine load that has to be divided by the number of bearing points and the resulting BW-Fixator® size has to be used everywhere under the machine.

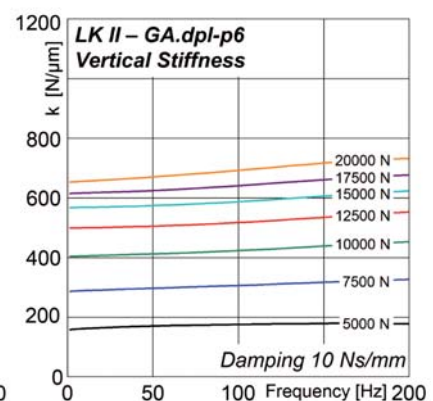
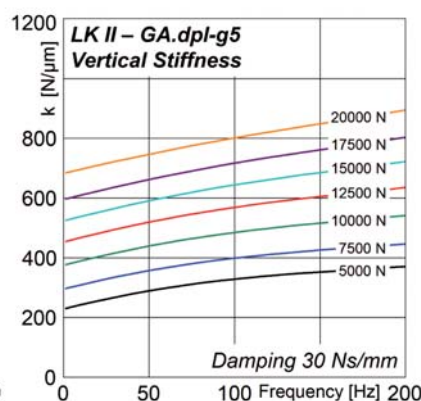
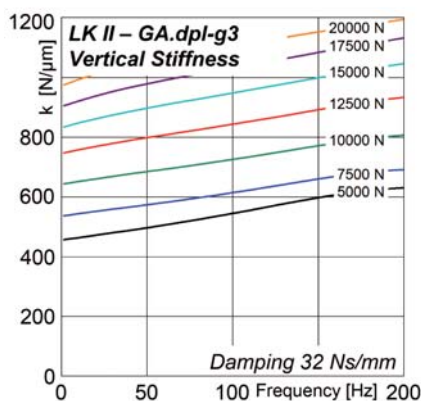
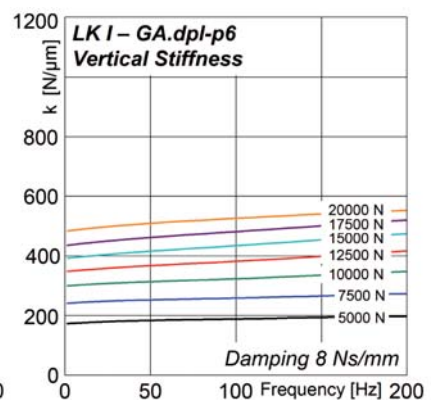
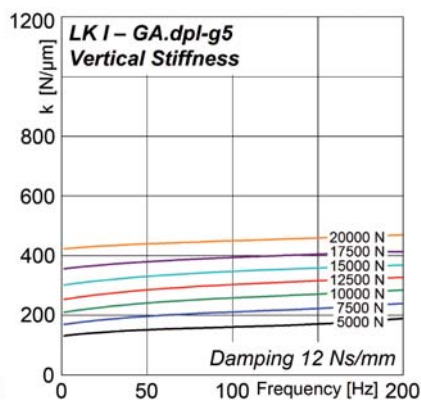
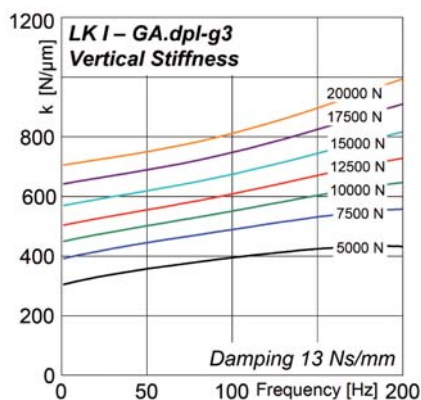

Horizontal stiffness values and coefficients for the frequency-dependent spring-damper-model available on request

Anchor bolts and studs

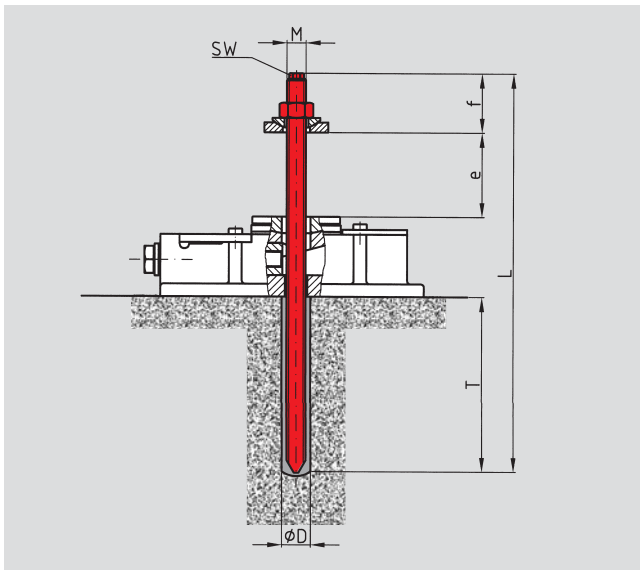

due

Resin anchor
(Capsule and stud)

LK	M	L	SW	f	e		Hole		Max. Torque Nm	Clamping Force max. N
					from	to	Ø D	T		
I	M12	250	8	30	0	60	14	110	30	10 000
II	M16	300	10	35	0	80	18	125	60	15 000

*Concrete >= B25

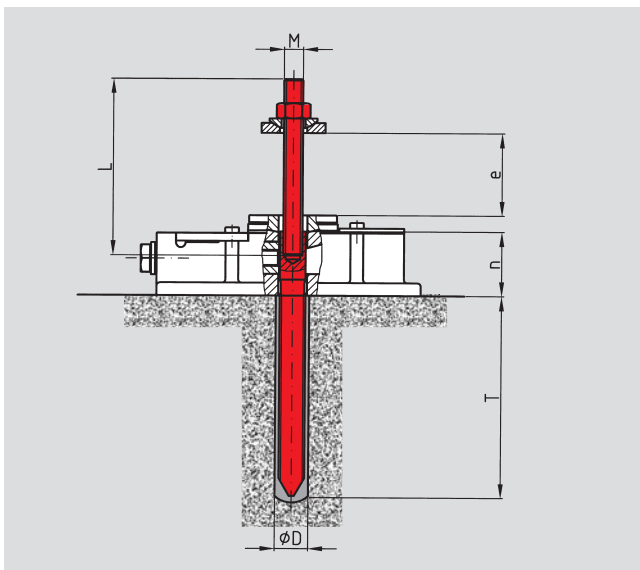

due/2

Split resin anchor
(Capsule and split stud)

Note:
Specify dimension "e"
(thickness of machine leg)
in your order

LK	M	L	n	e		Hole		Max. Torque Nm	Clamping Force max. N
				from	to	Ø D	T		
I	M12	130	40	0	70	18	125	30	10 000
II	M16	150	40	0	70	18	125	60	15 000

*Concrete >= B25

Anchor bolts and studs

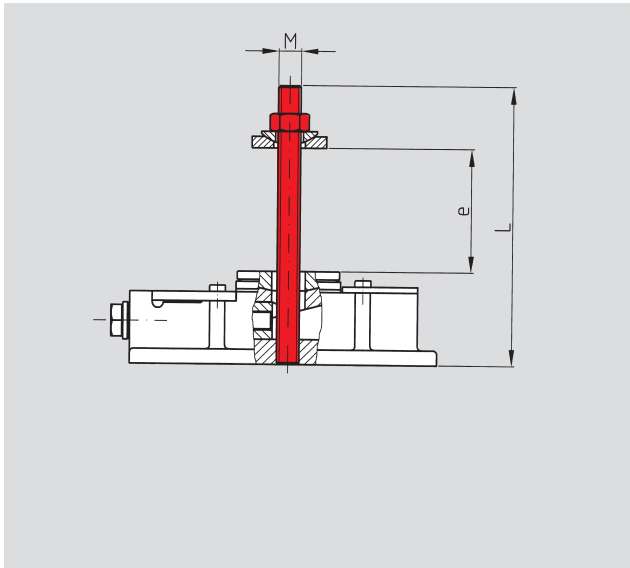

ste

Short or long stud bolt for attaching the machine to the BW-Fixator®

Note:
Specify dimension "e"
(thickness of machine leg)
in your order

LK	M	L			L			Max. Torque Nm	Clamping Force max. N
		short	from	to	long	from	to		
I	M12	130	0	50	160	55	80	30	10 000
II	M16	150	0	50	180	55	80	60	15 000

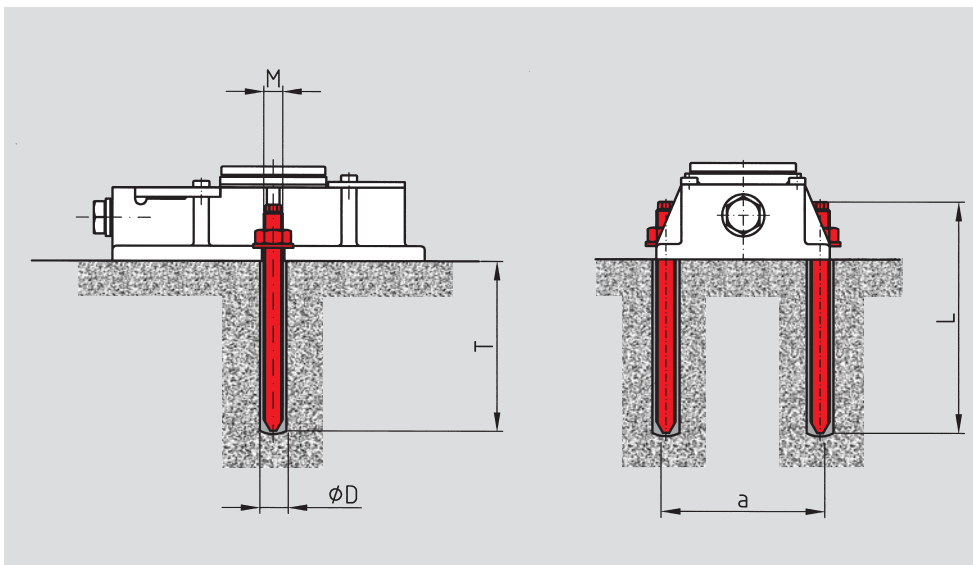

C

Side anchor bolts for connecting BW-Fixator® to the foundation
2 resin anchors
and 2 studs

LK	M	L	a	Hole		Max. Torque Nm	Clamping Force max. N
				Ø D	T		
I	M10	130	80	12	90	20	14 000
II	M12	160	950	14	110	30	20 000

Other Applications

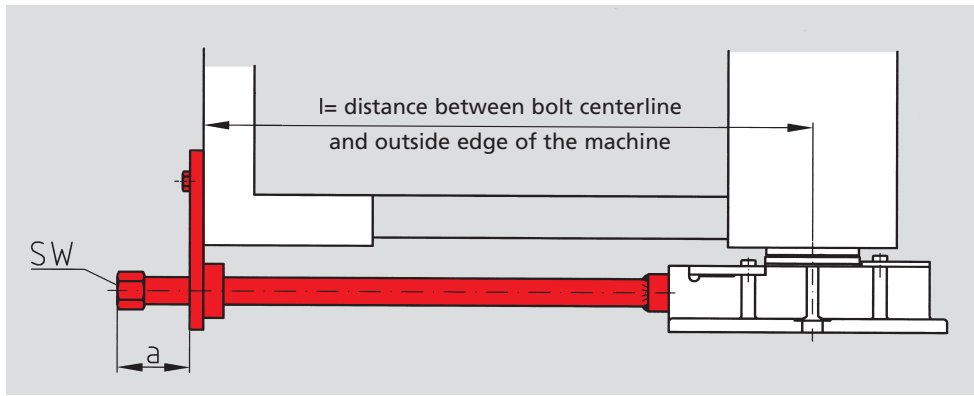

le

Extended set screw on BW-Fixator® arranged inwards of the machine side

LK	a	SW	Lenght	
			min. l	Tube
I	50	22	140	24x4
II	50	22	150	24x4

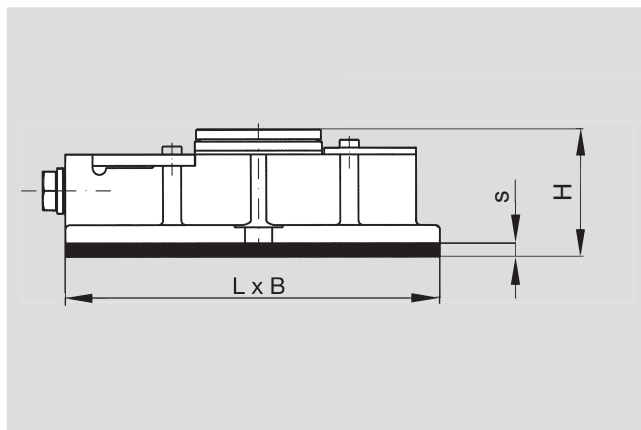

dpl - g - (s)

Isolating plate for not anchored machine installation

Thickness s available with 1, 3, 5 mm

Material: bituminous textile

LK	L	B	H
I	160	87	50+s
II	190	107	60+s

Specify in order s and if the plate shall be stuck to the Fixator bottom

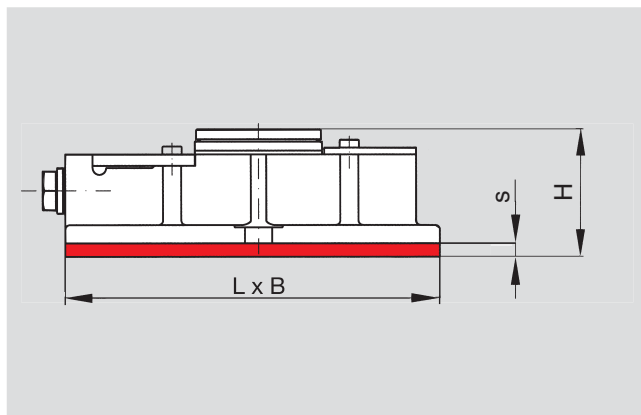

dpl - p

Isolating plate for not anchored machine installation

Material: Polyurethan

LK	L	B	s	H
I	160	87	6	56
II	190	107	6	66

The plate is stuck to the Fixator bottom

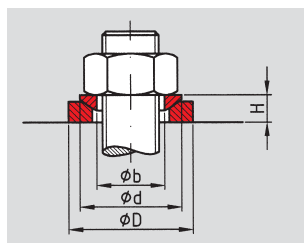

p Spherical washer set for non-parallel bearing surfaces

LK	ϕD	H	ϕd	b
I	40	9	30	13
II	40	9	30	17

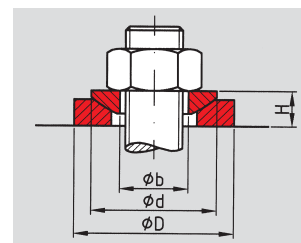

r Large spherical washer set for non-parallel bearing surfaces

LK	ϕD	H	ϕd	ϕb
I	-	-	-	-
II	44	10	36	17